

INSTALLATION

Single Chaining

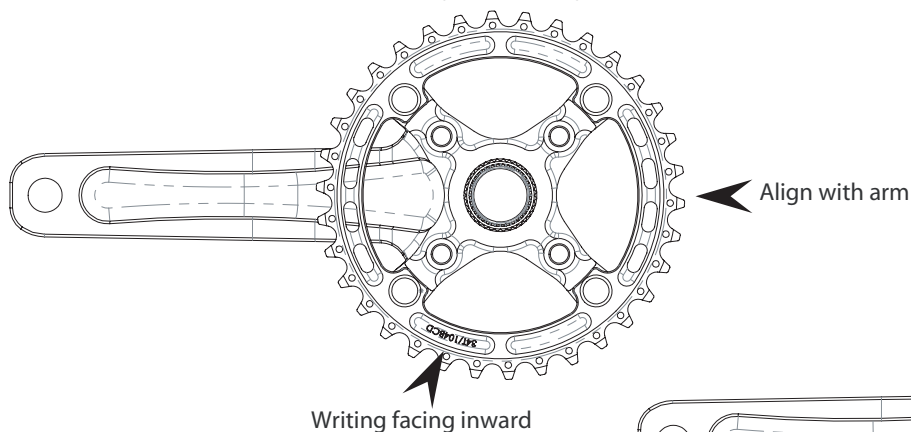

Retainer Ring

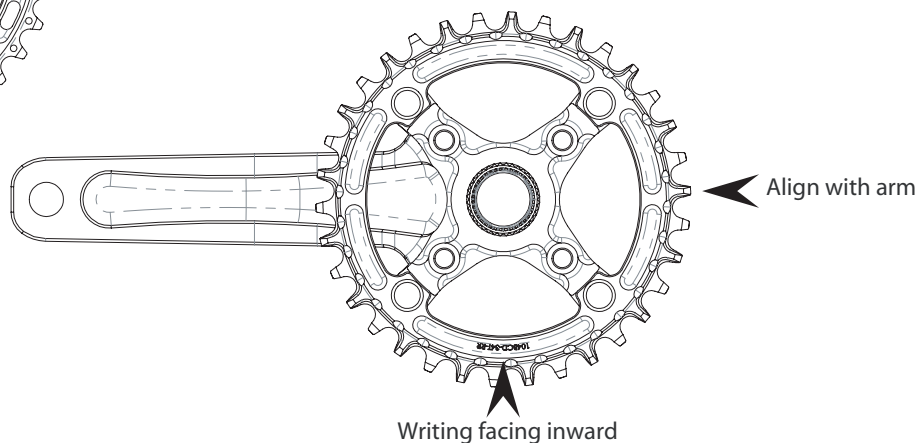

1. Install the chainring so the engraved writing and chainring bolt counterbore is facing inward. Note that the 30T Retainer Ring doesn't have any counterbore so make sure the engraved writing is facing inward.
2. For the Single Chaining align the see through pockets with the crank arm. For the Retainer Ring, align the split pocket with the crank arm.
3. Install the chainring bolts. Make sure the chainring bolts are the correct length to ensure enough thread engagement or not too long which could prevent proper tightening. In a cross pattern, tighten the 4 chainring bolts to manufacturer recommended torque (usually 10-12 N.m for steel chainring bolts).
4. Make sure the chainring seats perfectly flush to the spider. There should be no play at all. If there is any, it is very likely that the chainring bolts used are too long.

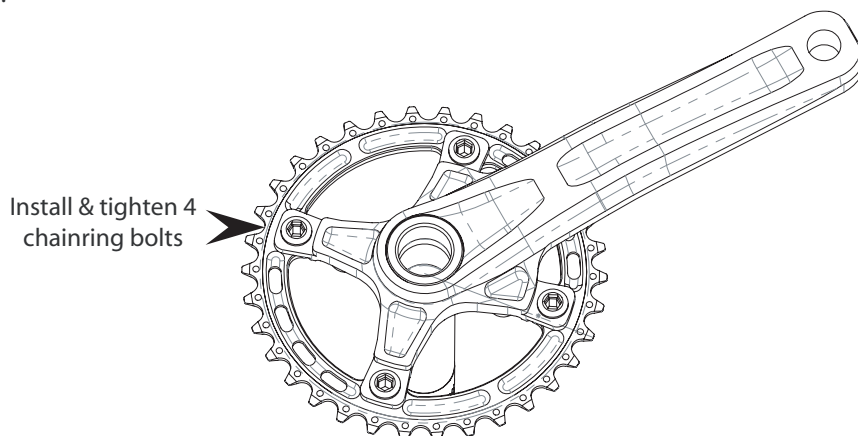

Note : After re-installing your chainset and chain, to minimise the chainring wear you may need to adjust the chainline. This depends on the range of cogs used on the rear but to adjust the chainline we recommend inserting some shims between the chainring and crankset spider.

WARRANTY

All Hope Technology components are covered for two years from original date of purchase against manufacturer defects in material and workmanship.

Proof of purchase is required. Products must be returned to the original place of purchase or to Hope Technology to process any warranty claim.

Please print and fill the "goods returned form" found on the tech support section of our website should you wish to send a product back.

This warranty does not cover any damage caused through normal wear, mis-use or failing to comply by the recommendations given.

This warranty does not affect your statutory rights.